



11 INDUSTRY DRIVE
PALM COAST, FL 32137
PHONE 877.900.7278
FAX 386.445.1122

INSTALLATION INSTRUCTIONS

Ford Hi-Torque Starter

#620-70109

REMOVAL OF THE ORIGINAL STARTER

1. CAUTION! Before proceeding, the negative (-) or ground terminal must be removed from the battery. Failure to do so can result in damage to the vehicle and/or injury to the installer!
2. Remove the large cable from the starter motor.
3. Remove the two (2) mounting bolts holding the starter to the engine (some Ford motors may be equipped with three mounting bolts).

INSTALLATION OF THE HI-TORQUE STARTER MOTOR

1. Run an appropriate tap through the mounting bolt holes to clean out any grease or debris.
2. Temporarily attach the mounting plate to the engine using the original bolts (Figure 3). NOTE: Big block Fords use the 906T mounting flange, which has a threaded hole. At this point DO NOT bolt the starter to the mounting plate. Hold the starter motor temporarily up into position on the mounting plate. While holding the starter motor in place, check for clearance between the starter and the engine block, and between the headers/exhaust system. NOTE: There are eighteen mounting holes located at 20 degree increments. Rotate the starter until you have roughly equal clearance on both sides of the motor. Using a felt tipped marker, mark across the mounting plate and the body of the starter motor. Remove the starter motor and the mounting plate from the engine. Position the mounting plate onto the starter motor. Install the two 5mm allen screws into the pair of holes which allow the closest alignment of the previously made marks. Using a metric allen wrench, temporarily tighten the bolts.
3. End clearance between the ring gear and the pinion gear teeth in the retracted position is critical (Figure 2). On the Hi-Torque starter, the pinion gear extends past the mounting plate flange by $\frac{1}{2}$ " in the retracted position. The distance from the motor mount plate to the front edge of the ring gear must be measured (Figure 4). Calculate the clearance by subtracting $\frac{1}{2}$ " from this dimension. If you are using the spacer ring (Figure 3) in your installation, then subtract an additional 0.4". The clearance should be between .040" to .100". If the measurement is less than this, you will have to add a circular shim (supplied with starter) between the starter motor and the mounting plate. Each shim is .074" thick. After determining the proper number of shims, apply Loctite 262 (or equivalent) to the bolts and tighten them to 95 IN/LBS. We recommend that you use a 4mm or 5mm hex driver with an inch pound torque wrench to do this.
4. Using the original mounting bolts, install the starter motor. Tight the bolts evenly to 25 FT/LBS.

ELECTRICAL CONNECTIONS

1. Most boats are equipped with a remote solenoid, if this is your case make a jumper using a pig tail (not included). Crimp the supplied ring terminal onto the stripped end of the pig tail lead. Plug the pigtail connector into the black plastic receptacle on the side of the solenoid. The ring connector attaches to the B+ terminal of the starter. Ensure there are no loose wires touching any "grounded" areas of the vehicle. Also, ensure the wiring is not in a position that it could rub against the block, frame or exhaust system. Re-route if required.
2. If you are not running a remote solenoid, make a connection to your ignition trigger wire. Finally, the battery must be fully charged and properly grounded to the engine block or frame.
3. Reconnect the negative (-) terminal to the battery and test for proper operation.

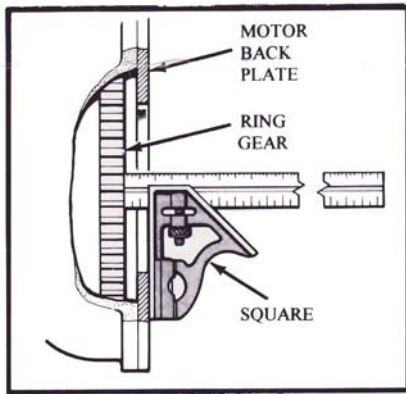

FIGURE 4

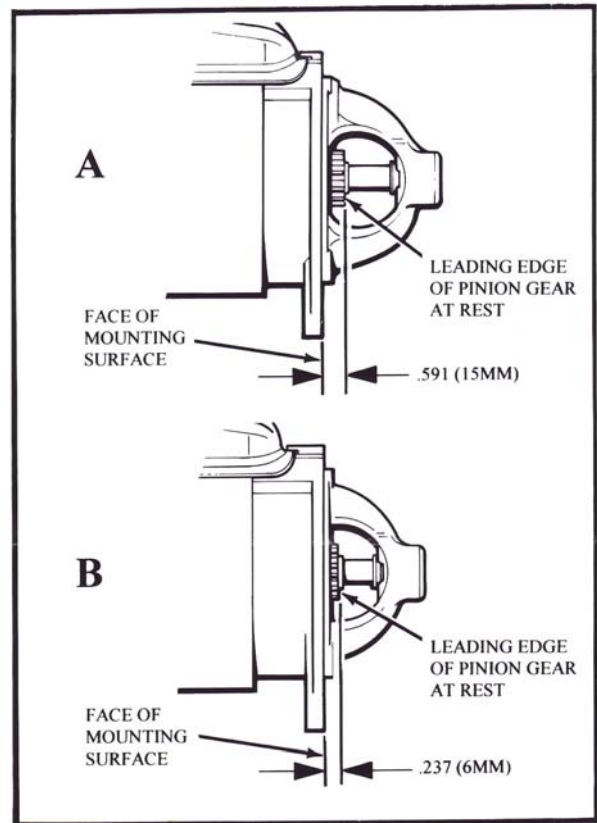

FIGURE 1

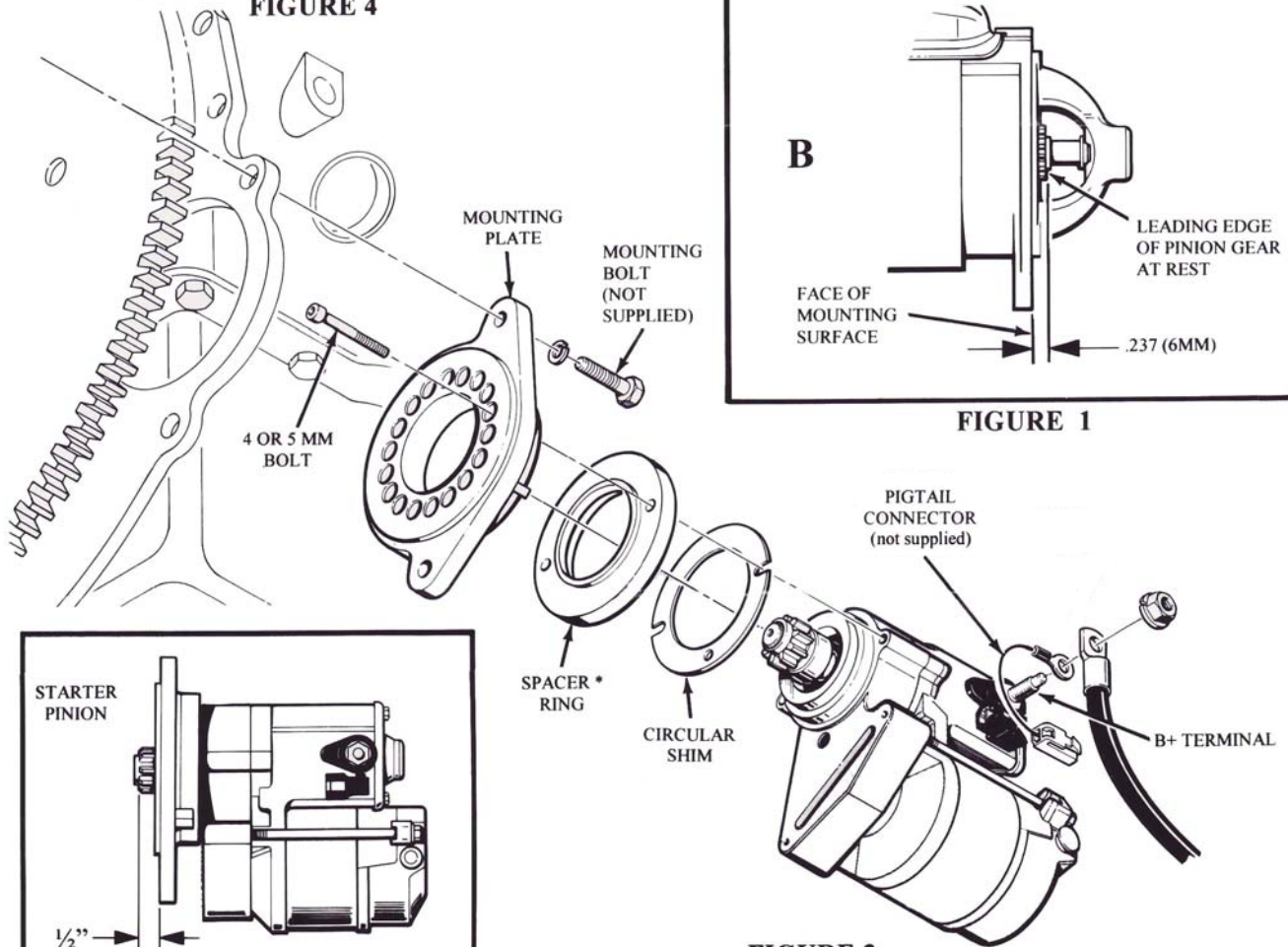

FIGURE 3

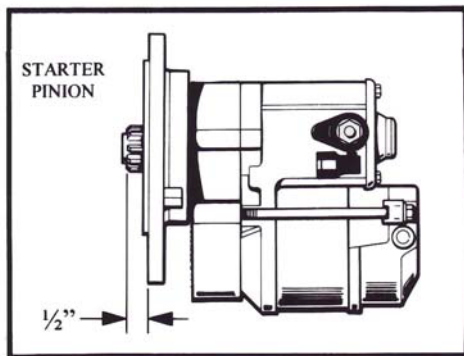

FIGURE 2