

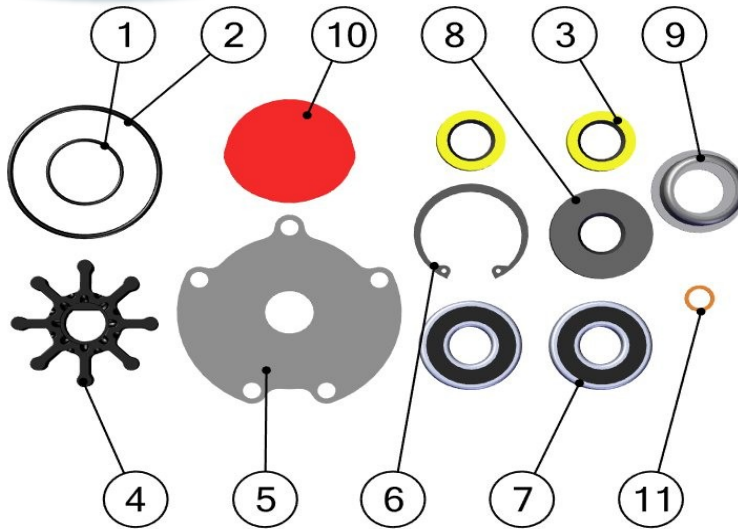

HARDIN GEN 5/6 MASTER REBUILD KIT

625-4175



Description	BOM ID	Qty
625-1026	1	1
625-1145	2	1
625-4005	3	2
625-4011	4	1
625-4018	5	1
625-4077	6	1
625-4078	7	2
625-4079	8	1
625-4092	9	2
625-4265	10	1
90037SA-STCO	11	1

- Step 1:**

1) Using 1/2 socket remove bolts and washers.

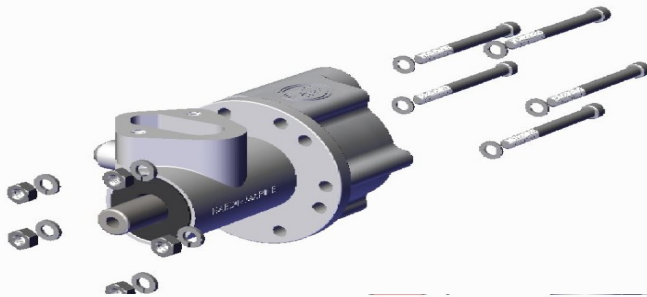

- Step 2:**

1) Remove housing, impeller, wear plates and o-rings.

2) Discard parts.

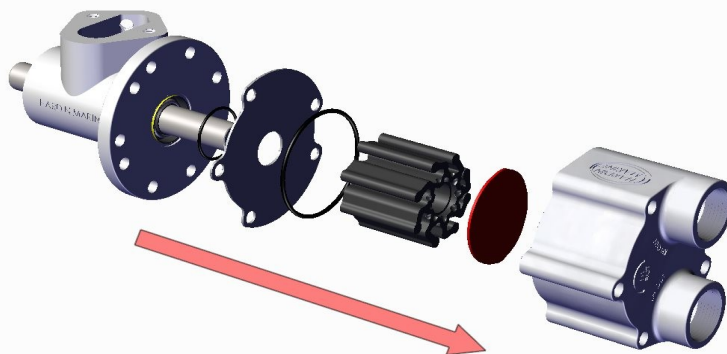



HARDIN GEN 5/6 MASTER REBUILD KIT

625-4175

- **Step 3:**

1) Use a screwdriver to remove the front seal.

2) Use snap ring pliers to remove snap ring.

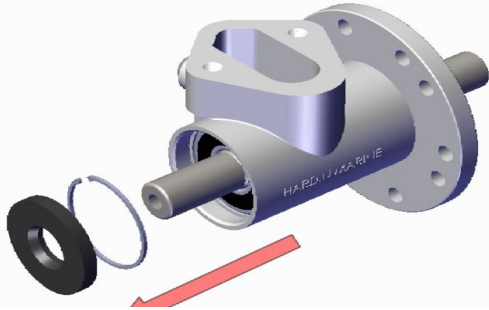

- **Step 4:**

1) Press shaft out of the housing.

2) Remove bearings and wear ring from the shaft and discard.

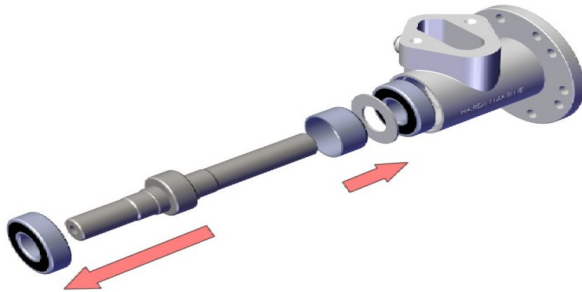

- **Step 5:**

1) These are all the new parts for the front snout assembly.

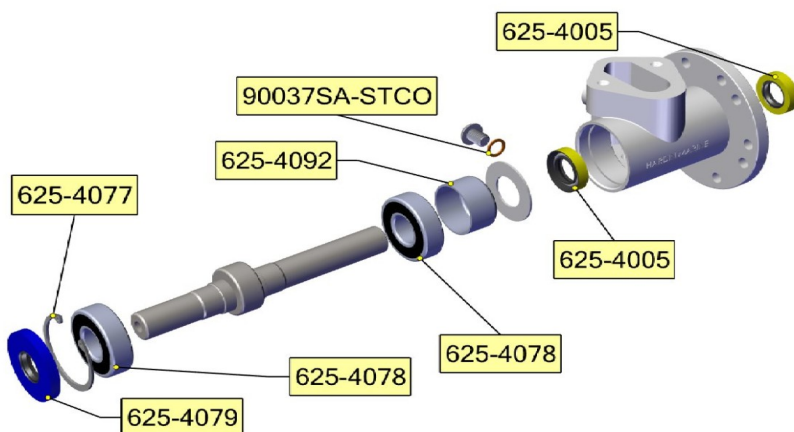



HARDIN GEN 5/6 MASTER REBUILD KIT

625-4175

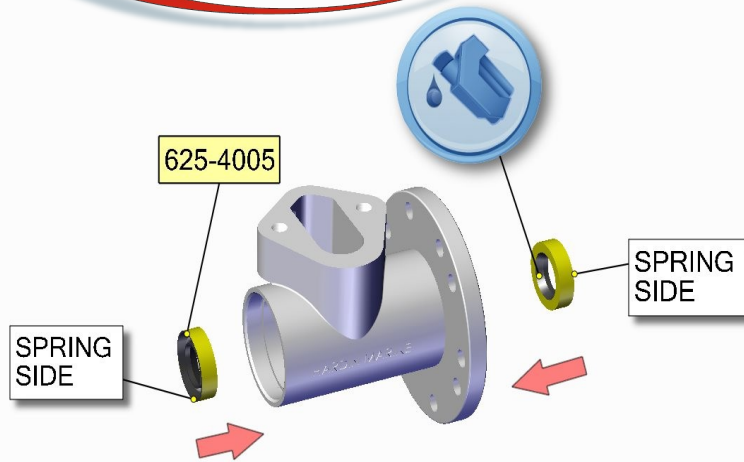

- **Step 6:**
 - 1) Remove both seals and clean the housing.
 - 2) Make sure the seals are flush with the inside and back side of the bearing housing.
 - 3) Install with the spring side of the seals to the outside of the housing.
 - 4) Coat seals with petroleum jelly

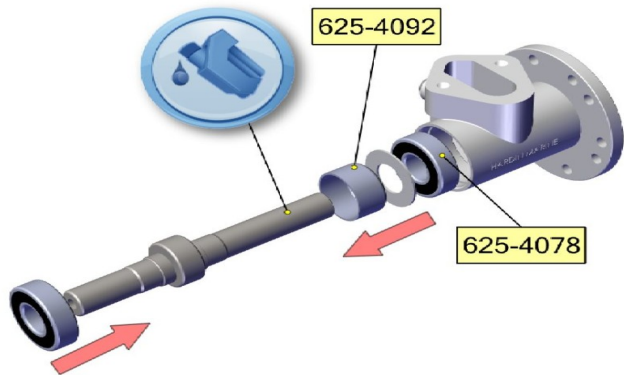

- **Step 7:**
 - 1) Slide new wear ring and washer from the rear of the shaft.
 - 2) Press the new bearings on the shaft.
 - 2) Coat bearings with grease and install shaft into the housing.

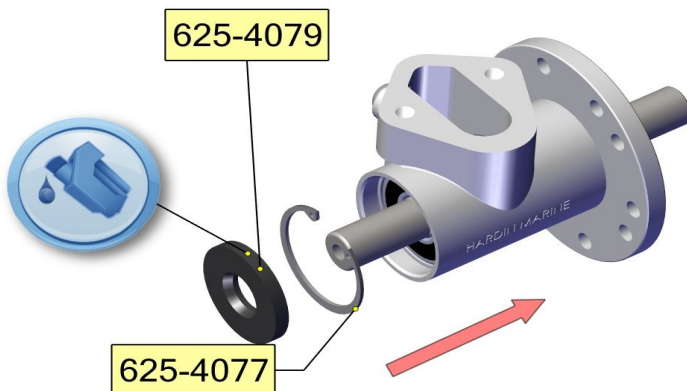

- **Step 8:**
 - 1) Using snap ring pliers, install the new snap ring
 - 2) Coat seal with petroleum jelly and install flush with housing.



HARDIN GEN 5/6 MASTER REBUILD KIT

625-4175

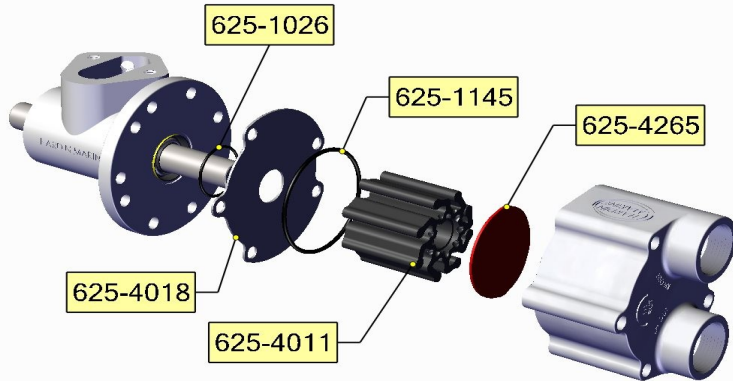

- **Step 9:**
1) This is the list of the new parts and the order of assembly.

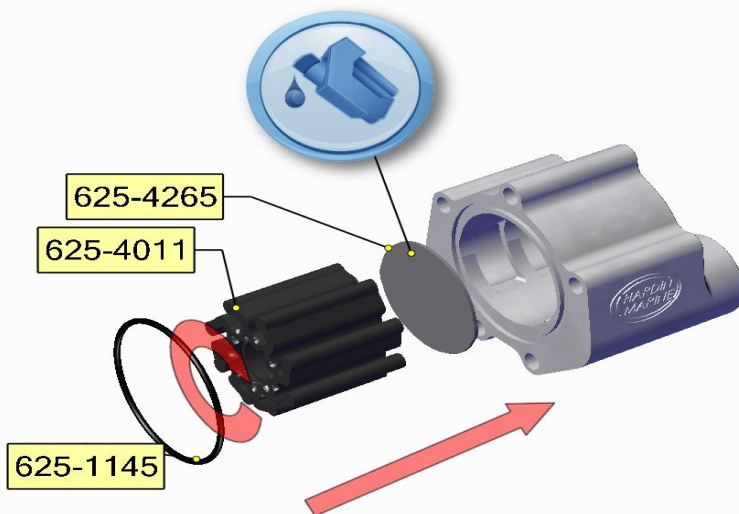

- **Step 10:**
1) Install rear plate into the housing. Coat with petroleum jelly.
2) Coat inside of housing with petroleum jelly. Install impeller into the housing. Rotate clockwise like shown for standard rotation engine, port side mounted sea pump.
3) Coat o-ring with petroleum jelly and install into the groove in the housing.

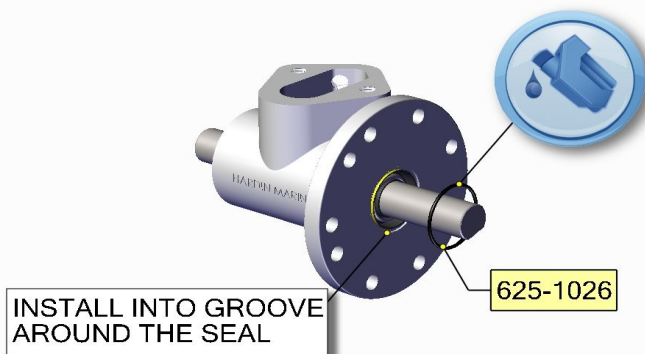

- **Step 11:**
1) Coat o-ring with petroleum jelly and install into the groove around the groove around the seal.



HARDIN GEN 5/6 MASTER REBUILD KIT

625-4175

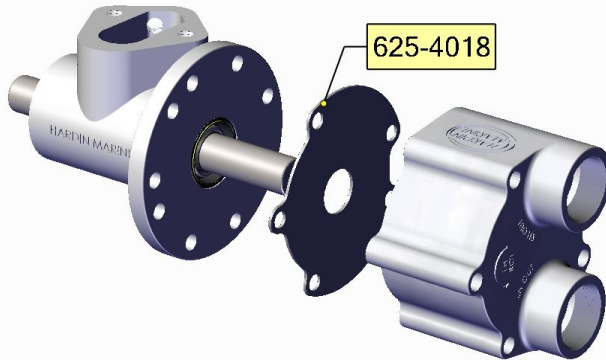

- **Step 12:**
 - 1) Slide wear plate over the shaft.
 - 2) Make sure the impeller side of the wear plate is coated with petroleum jelly.
 - 3) Install sea pump impeller housing.

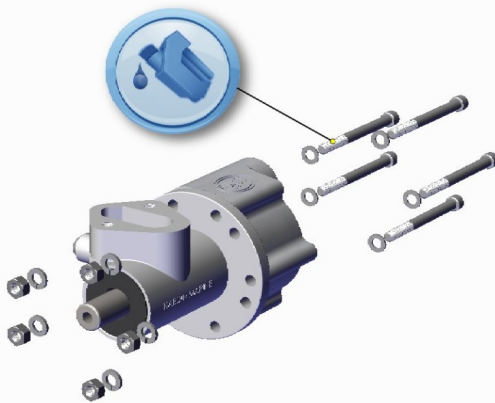

- **Step 13:**
 - 1) Apply anti-sieze to the bolts.
 - 2) Using 1/2 socket install bolts and nuts. Once installed into the bracket torque to 20 ft. lbs..
 - 3) The front of the sea pump is threaded for reinstalling sea pump pulley using the power steering pulley installer.

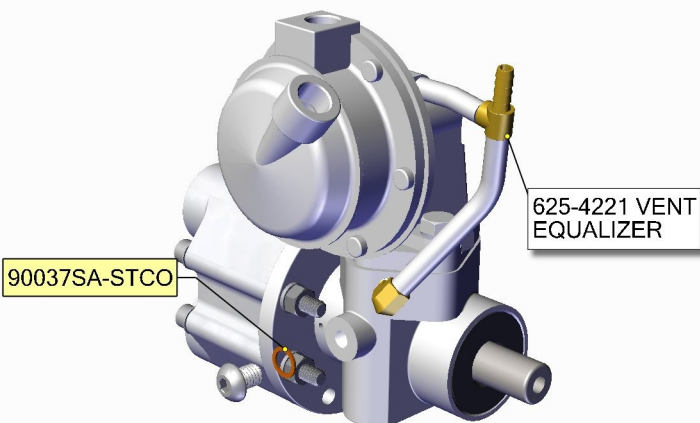

- **Step 14:**
 - 1) Fill cavity with Quicksilver High Performance Gear Lube until the lube pours out of the theads.
 - 2) Using 7/32 hex socket install bolt with new copper washer.
 - 3) Install fuel pump and vent equalizer.